

Standardverschraubungen Typ100

Standard fittings Type 100



Features

- ▶ **Verschraubungen aus Messing**
- ▶ **für Anschlussmöglichkeiten von M5 bis G1"**
- ▶ **hohe Belastbarkeit**
- ▶ **Korrosionsschutz durch Vernickelung**

- ▶ **Brass fittings**
- ▶ **For connections from M5 to G1"**
- ▶ **High resilience**
- ▶ **Nickel-plating for corrosion protection**

Technische Daten Technical data

| | | |
|-----------------------|---|--|
| Betriebstemperatur | max. +150°C | abhängig von Temperaturbereich des eingesetzten Schlauches/Rohres |
| Betriebsdruck | bis 60bar | abhängig vom Druckbereich des eingesetzten Schlauches/ Rohres und der verwendeten Temperatur |
| Werkstoffe | Messing (Ms58) vernickelt bzw. blank | |
| Gewinde | zyl. Gew. DIN EN ISO 228 kon. Gew. DIN EN 10226 (ISO7 / DIN 2999) metr. Gew. DIN ISO 262 | |
| Medium | pneumatische, ölhydraulische und hydraulische Kreisläufe | |
| Operating temperature | Max +150°C | Dependent on the temperature range of the tube/pipe used |
| Operating pressure | Up to 60 bar | Dependent on the pressure range of the tube/pipe used and the temperature used |
| Materials | Brass (Ms58), nickel-plated or polished | |
| Thread | Cyl. thread, DIN EN ISO 228 Con. thread, DIN EN 10226 (ISO7 / DIN 2999) Metr. thread, DIN ISO 262 | |
| Medium | Pneumatic, oil-hydraulic and hydraulic circuits | |

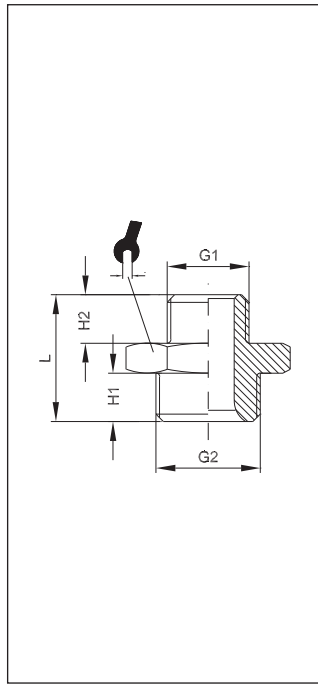

101

Doppelnippel zylindrisch

Double nipple cyl.

| TV | G1 | G2 | H1 | H2 | L | | |
|-------|-------------------------------|-------------------------------|----|----|------|----|-----|
| 20101 | M5 | M5 | 4 | 4 | 11,5 | 8 | 100 |
| 20302 | M5 | G ¹ / ₈ | 6 | 4 | 14,5 | 14 | 100 |
| 20102 | G ¹ / ₈ | G ¹ / ₈ | 6 | 6 | 16,5 | 14 | 100 |
| 20303 | G ¹ / ₈ | G ¹ / ₄ | 8 | 6 | 19 | 17 | 100 |
| 20304 | G ¹ / ₈ | G ³ / ₈ | 9 | 6 | 20 | 19 | 100 |
| 20103 | G ¹ / ₄ | G ¹ / ₄ | 8 | 8 | 21 | 17 | 100 |
| 20305 | G ¹ / ₄ | G ³ / ₈ | 9 | 8 | 22 | 19 | 100 |
| 20306 | G ¹ / ₄ | G ¹ / ₂ | 10 | 8 | 23,5 | 24 | 100 |
| 20104 | G ³ / ₈ | G ³ / ₈ | 9 | 9 | 23 | 19 | 100 |
| 20307 | G ³ / ₈ | G ¹ / ₂ | 10 | 9 | 24,5 | 24 | 50 |
| 20105 | G ¹ / ₂ | G ¹ / ₂ | 10 | 10 | 25,5 | 24 | 50 |

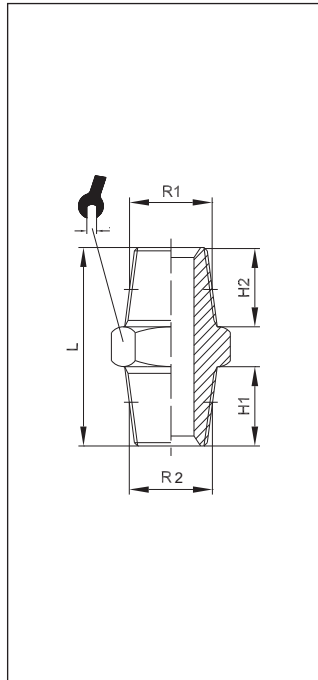

102

Doppelnippel konisch

Double nipple con.

| TV | R1 | R2 | H1 | H2 | L | | |
|-------|-------------------------------|-------------------------------|------|------|------|----|-----|
| 20002 | R ¹ / ₈ | R ¹ / ₈ | 8 | 8 | 20,5 | 12 | 100 |
| 20202 | R ¹ / ₈ | R ¹ / ₄ | 11 | 8 | 24 | 14 | 100 |
| 20203 | R ¹ / ₈ | R ³ / ₈ | 11,5 | 8 | 24,5 | 17 | 100 |
| 20204 | R ¹ / ₈ | R ¹ / ₂ | 14 | 7,5 | 27 | 22 | 100 |
| 20003 | R ¹ / ₄ | R ¹ / ₄ | 11 | 11 | 27 | 14 | 100 |
| 20205 | R ¹ / ₄ | R ³ / ₈ | 11,5 | 11 | 27,5 | 17 | 100 |
| 20206 | R ¹ / ₄ | R ¹ / ₂ | 14 | 11 | 30,5 | 22 | 100 |
| 20004 | R ³ / ₈ | R ³ / ₈ | 11,5 | 11,5 | 28 | 17 | 100 |
| 20207 | R ³ / ₈ | R ¹ / ₂ | 14 | 11,5 | 31 | 22 | 100 |
| 20005 | R ¹ / ₂ | R ¹ / ₂ | 14 | 14 | 33,5 | 22 | 50 |
| 20208 | R ¹ / ₂ | R ³ / ₄ | 16 | 14 | 37 | 27 | 50 |
| 20006 | R ³ / ₄ | R ³ / ₄ | 16 | 16 | 39,5 | 27 | 25 |
| 20209 | R ³ / ₄ | R1 | 19 | 16,5 | 42,5 | 34 | 25 |
| 20007 | R1 | R1 | 19 | 19 | 45,5 | 34 | 25 |

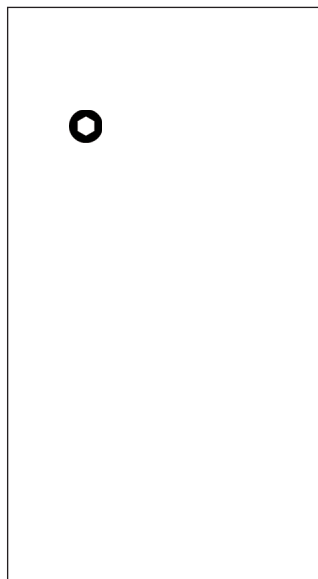

103

Muffe

Sleeve

| TV | G | L | | |
|-------|-------------------------------|----|----|-----|
| 30001 | M5 | 11 | 8 | 100 |
| 30002 | G ¹ / ₈ | 15 | 14 | 100 |
| 30003 | G ¹ / ₄ | 22 | 17 | 100 |
| 30004 | G ³ / ₈ | 23 | 22 | 100 |
| 30005 | G ¹ / ₂ | 28 | 26 | 50 |
| 30006 | G ³ / ₄ | 32 | 32 | 50 |

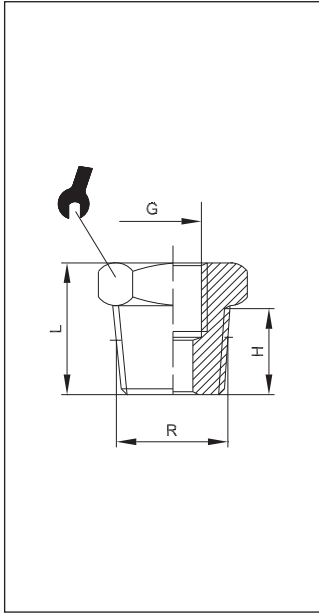

104

Reduzierung konisch

Reducer con.

| TV | R | G | H | L | | |
|-------|------------------|------------------|------|------|----|-----|
| 20801 | R ^{1/4} | G ^{1/8} | 11 | 16 | 14 | 100 |
| 20802 | R ^{3/8} | G ^{1/8} | 11,5 | 16,5 | 17 | 100 |
| 20803 | R ^{1/2} | G ^{1/8} | 14 | 19,5 | 22 | 50 |
| 20804 | R ^{3/8} | G ^{1/4} | 11,5 | 16,5 | 17 | 100 |
| 20805 | R ^{1/2} | G ^{1/4} | 14 | 19,5 | 22 | 50 |
| 20806 | R ^{1/2} | G ^{3/8} | 14 | 19,5 | 22 | 50 |
| 20807 | R ^{3/4} | G ^{1/2} | 16,5 | 23 | 27 | 50 |
| 20808 | R1 | G ^{1/2} | 19 | 27,5 | 34 | 25 |
| 20809 | R1 | G ^{3/4} | 18,5 | 27,5 | 34 | 25 |
| 20810 | R ^{3/4} | G ^{3/8} | 16,5 | 23,5 | 27 | 25 |

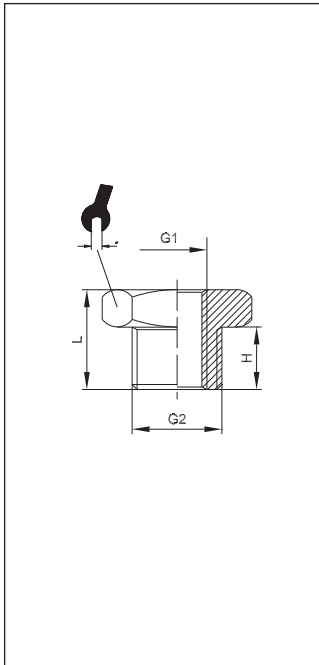

104/Z

Reduzierung zylindrisch

Reducer cyl.

| TV | G1 | G2 | H | L | | |
|-------|------------------|------------------|-----|------|----|-----|
| 20902 | M5 | G ^{1/8} | 6,0 | 10,5 | 14 | 100 |
| 20903 | G ^{1/8} | G ^{1/4} | 9 | 13 | 17 | 100 |
| 20904 | G ^{1/8} | G ^{3/8} | 9 | 14 | 19 | 100 |
| 20905 | G ^{1/4} | G ^{3/8} | 9 | 14 | 19 | 100 |
| 20906 | G ^{1/8} | G ^{1/2} | 10 | 15,5 | 24 | 100 |
| 20907 | G ^{1/4} | G ^{1/2} | 10 | 15,5 | 24 | 50 |
| 20908 | G ^{3/8} | G ^{1/2} | 10 | 15,5 | 24 | 50 |
| 20909 | G ^{3/8} | G ^{3/4} | 11 | 17,5 | 30 | 50 |
| 20910 | G ^{1/2} | G ^{3/4} | 11 | 17,5 | 30 | 50 |

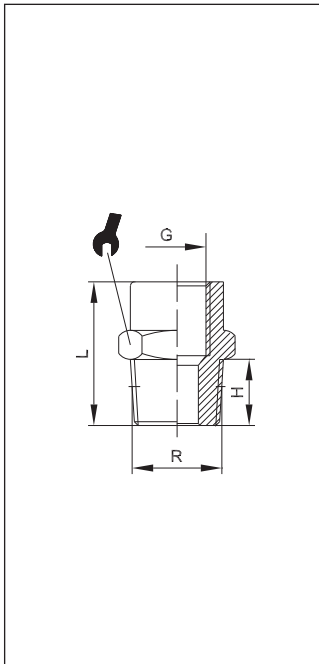

105

Verlängerung konisch

Extension con.

| TV | R | G | H | L | | |
|-------|------------------|------------------|------|------|----|-----|
| 20402 | R ^{1/8} | G ^{1/8} | 8 | 18 | 14 | 100 |
| 20403 | R ^{1/8} | G ^{1/4} | 8 | 21,5 | 17 | 100 |
| 20404 | R ^{1/8} | G ^{3/8} | 8 | 22,5 | 22 | 100 |
| 20405 | R ^{1/4} | G ^{1/4} | 11 | 24,5 | 17 | 100 |
| 20406 | R ^{1/4} | G ^{3/8} | 11 | 25,5 | 22 | 100 |
| 20407 | R ^{1/4} | G ^{1/2} | 11 | 29 | 24 | 50 |
| 20408 | R ^{3/8} | G ^{3/8} | 11,5 | 26 | 22 | 100 |
| 20409 | R ^{3/8} | G ^{1/2} | 11,5 | 29 | 24 | 50 |
| 20410 | R ^{1/2} | G ^{1/2} | 14 | 32 | 26 | 50 |
| 20411 | R ^{1/2} | G ^{3/4} | 14 | 35 | 32 | 50 |

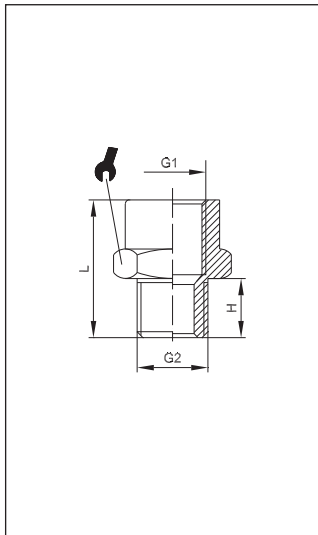

105/Z

Verlängerung zylindrisch

Parallel M/F extension

| TV | G1 | G2 | H | L | | |
|-------|-------------------------------|-------------------------------|----|------|----|-----|
| 20501 | G ¹ / ₈ | M5 | 4 | 14,5 | 14 | 100 |
| 20502 | G ¹ / ₈ | G ¹ / ₈ | 6 | 16 | 14 | 100 |
| 20503 | G ¹ / ₄ | G ¹ / ₈ | 6 | 19,5 | 17 | 100 |
| 20504 | G ³ / ₈ | G ¹ / ₈ | 6 | 20,5 | 22 | 100 |
| 20505 | G ¹ / ₄ | G ¹ / ₄ | 8 | 21,5 | 17 | 100 |
| 20506 | G ³ / ₈ | G ¹ / ₄ | 8 | 22,5 | 22 | 50 |
| 20507 | G ¹ / ₂ | G ¹ / ₄ | 8 | 26 | 24 | 100 |
| 20508 | G ³ / ₈ | G ³ / ₈ | 9 | 23,5 | 22 | 100 |
| 20509 | G ¹ / ₂ | G ³ / ₈ | 9 | 27 | 24 | 50 |
| 20510 | G ¹ / ₂ | G ¹ / ₂ | 10 | 28 | 26 | 50 |
| 20511 | G ³ / ₄ | G ¹ / ₂ | 11 | 28 | 32 | 25 |
| 20513 | G1 | G ³ / ₄ | 11 | 29 | 38 | 10 |

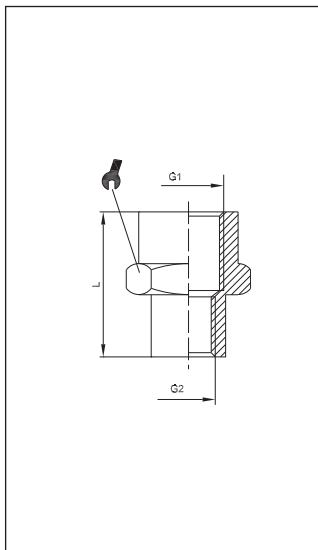

106

Verlängerung reduziert Innen-Innen

Reducing sleeve

| TV | G1 | G2 | L | | |
|-------|-------------------------------|-------------------------------|------|----|-----|
| 30101 | G ¹ / ₈ | M5 | 13,5 | 14 | 100 |
| 30102 | G ¹ / ₄ | G ¹ / ₈ | 19 | 17 | 100 |
| 30103 | G ³ / ₈ | G ¹ / ₈ | 20 | 22 | 50 |
| 30104 | G ¹ / ₂ | G ¹ / ₈ | 24 | 24 | 100 |
| 30105 | G ³ / ₈ | G ¹ / ₄ | 22,5 | 22 | 50 |
| 30106 | G ¹ / ₂ | G ¹ / ₄ | 26 | 24 | 50 |
| 30107 | G ¹ / ₂ | G ³ / ₈ | 26 | 24 | 50 |
| 30108 | G1 | G ¹ / ₂ | 39 | 40 | 25 |
| 30109 | G1 | G ³ / ₄ | 41 | 40 | 25 |
| 30110 | G ¹ / ₂ | G ³ / ₄ | 30 | 32 | 25 |

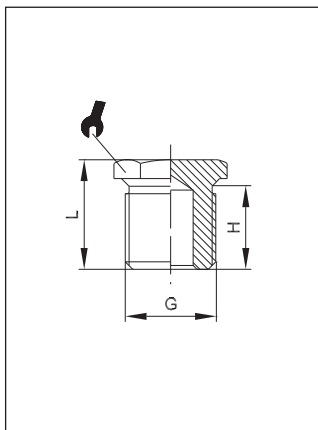

107

Stopfen

Parallel male plug

| TV | G | H | L | | |
|-------|-------------------------------|----|------|----|-----|
| 30201 | M5 | 4 | 7 | 8 | 100 |
| 30202 | G ¹ / ₈ | 6 | 10 | 14 | 100 |
| 30203 | G ¹ / ₄ | 8 | 12,5 | 17 | 100 |
| 30204 | G ³ / ₈ | 9 | 13,5 | 19 | 100 |
| 30205 | G ¹ / ₂ | 10 | 15,5 | 24 | 50 |
| 30206 | G ³ / ₄ | 11 | 16,5 | 30 | 25 |
| 30207 | G1 | 13 | 19 | 38 | 25 |

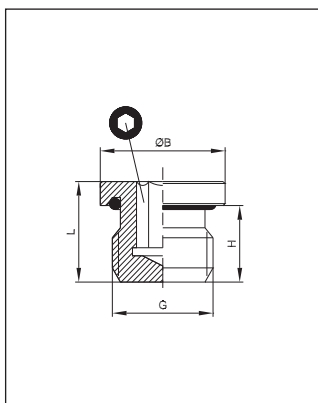

107 - OR

Stopfen mit O-Ring

Parallel male plug with O-ring

| TV | G | ØB | H | L | | |
|-------|-------------------------------|----|-----|------|-----|----|
| 30150 | M5 | 8 | 4,5 | 7,2 | 2,5 | 50 |
| 30151 | M7 | 11 | 6 | 9 | 4 | 50 |
| 30152 | G ¹ / ₈ | 14 | 6,5 | 9,5 | 5 | 50 |
| 30153 | G ¹ / ₄ | 17 | 8 | 11,5 | 6 | 50 |
| 30154 | G ³ / ₈ | 20 | 9 | 12,5 | 8 | 25 |
| 30155 | G ¹ / ₂ | 26 | 11 | 14 | 10 | 25 |

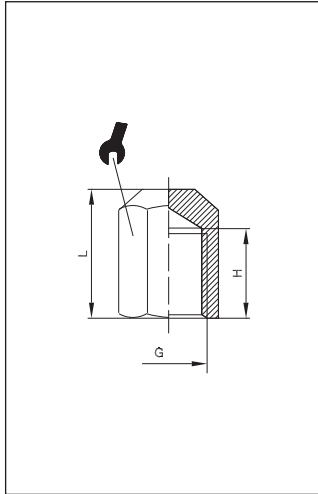

108

Kappe

Female plug

| TV | G | H | L | | |
|-------|-------------------------------|----|------|----|-----|
| 30302 | G ¹ / ₈ | 8 | 11,5 | 14 | 100 |
| 30303 | G ¹ / ₄ | 11 | 15 | 17 | 100 |
| 30304 | G ³ / ₈ | 12 | 15,5 | 20 | 50 |
| 30305 | G ¹ / ₂ | 14 | 20 | 24 | 50 |

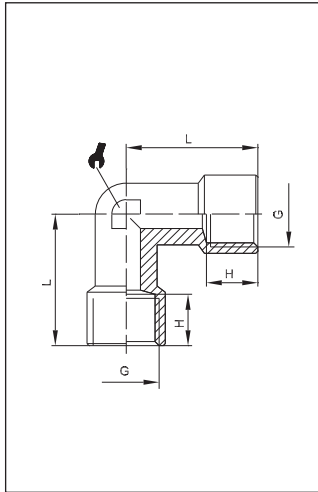

109

Winkelstück

Female elbow

| TV | G | H | L | | |
|-------|-------------------------------|------|------|----|-----|
| 50102 | G ¹ / ₈ | 8 | 21 | 10 | 100 |
| 50103 | G ¹ / ₄ | 11 | 25,5 | 13 | 50 |
| 50104 | G ³ / ₈ | 11,5 | 28 | 17 | 25 |
| 50105 | G ¹ / ₂ | 14 | 33,5 | 21 | 25 |
| 50106 | G ³ / ₄ | 16,5 | 36,5 | 25 | 25 |
| 50107 | G1 | 19 | 45 | 30 | 25 |

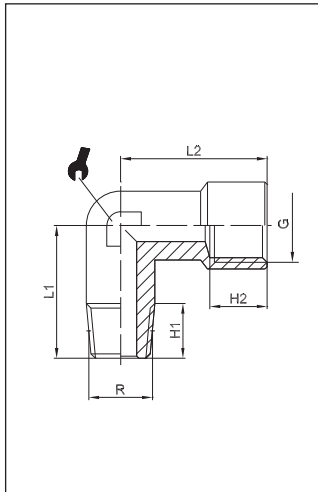

110

Winkelstück

Male-female elbow

| TV | R | G | H1 | H2 | L1 | L2 | | |
|-------|-------------------------------|-------------------------------|------|------|------|------|----|-----|
| 50201 | M5 | M5 | 4 | 4 | 11,5 | 11 | 9 | 100 |
| 50208 | R ¹ / ₄ | G ¹ / ₈ | 11 | 8 | 21,5 | 21 | 10 | 100 |
| 50202 | R ¹ / ₈ | G ¹ / ₈ | 8 | 8 | 18,5 | 21 | 10 | 100 |
| 50203 | R ¹ / ₄ | G ¹ / ₄ | 11 | 11 | 23,5 | 25,5 | 13 | 50 |
| 50204 | R ³ / ₈ | G ³ / ₈ | 11,5 | 11,5 | 26 | 28 | 17 | 25 |
| 50205 | R ¹ / ₂ | G ¹ / ₂ | 14 | 14 | 31 | 33,5 | 21 | 25 |
| 50206 | R ³ / ₄ | G ³ / ₄ | 16 | 16,5 | 33 | 36,5 | 25 | 10 |
| 50207 | R1 | R1 | 17 | 19 | 39 | 45 | 30 | 10 |

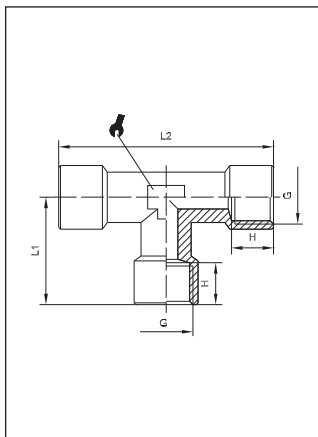

111

T-Stück

Female Tee

| TV | G | H | L1 | L2 | | |
|-------|-------------------------------|------|------|----|----|-----|
| 40003 | G ¹ / ₈ | 8 | 21 | 42 | 10 | 100 |
| 40004 | G ¹ / ₄ | 11 | 25,5 | 51 | 13 | 50 |
| 40005 | G ³ / ₈ | 11,5 | 28 | 56 | 17 | 25 |
| 40006 | G ¹ / ₂ | 15 | 33,5 | 67 | 21 | 25 |
| 40007 | G ³ / ₄ | 16,5 | 36,5 | 73 | 25 | 10 |
| 40008 | G1 | 19 | 45 | 90 | 30 | 10 |

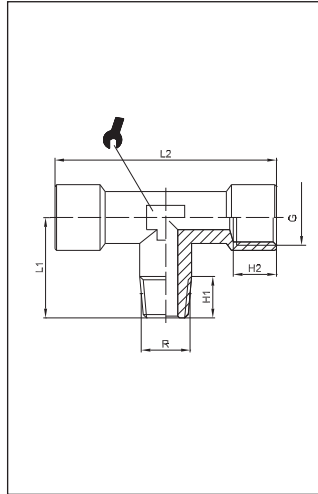

112

T-Stück konisch

Centre male Tee, con.

| ITV | R | G | H1 | H2 | L1 | L2 | | |
|-------|------------------|------------------|------|------|------|----|----|-----|
| 40401 | M5 | M5 | 5 | 4 | 11,5 | 22 | 9 | 100 |
| 40402 | R ^{1/8} | G ^{1/8} | 8 | 8 | 18,5 | 42 | 10 | 100 |
| 40403 | R ^{1/4} | G ^{1/4} | 11 | 11 | 23,5 | 51 | 13 | 50 |
| 40404 | R ^{3/8} | G ^{3/8} | 11,5 | 11,5 | 26 | 56 | 17 | 25 |
| 40405 | R ^{1/2} | G ^{1/2} | 14 | 14 | 31 | 67 | 21 | 25 |
| 40406 | R ^{3/4} | G ^{3/4} | 16 | 16,5 | 33 | 73 | 25 | 10 |
| 40407 | R1 | G1 | 17,5 | 19 | 39 | 90 | 30 | 10 |

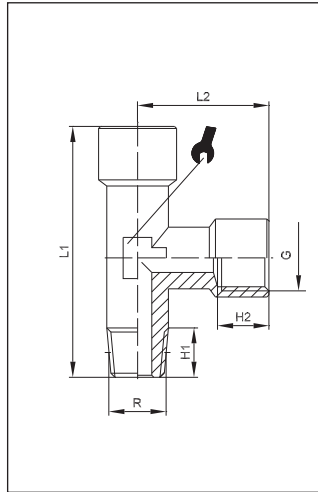

113

L-Stück konisch

Off-set male T-MFF, con.

| ITV | R | G | H1 | H2 | L1 | L2 | | |
|-------|------------------|------------------|------|------|------|------|----|-----|
| 40502 | R ^{1/8} | G ^{1/8} | 8 | 8 | 39,5 | 21 | 10 | 100 |
| 40503 | R ^{1/4} | G ^{1/4} | 11 | 11 | 49 | 25,5 | 13 | 50 |
| 40504 | R ^{3/8} | G ^{3/8} | 11,5 | 11,5 | 54 | 28 | 17 | 25 |
| 40505 | R ^{1/2} | G ^{1/2} | 14 | 14 | 64,5 | 33 | 21 | 25 |
| 40506 | R ^{3/4} | G ^{3/4} | 16 | 16,5 | 69,5 | 36,5 | 25 | 10 |
| 40507 | R1 | G1 | 17,5 | 19 | 84 | 45 | 30 | 10 |

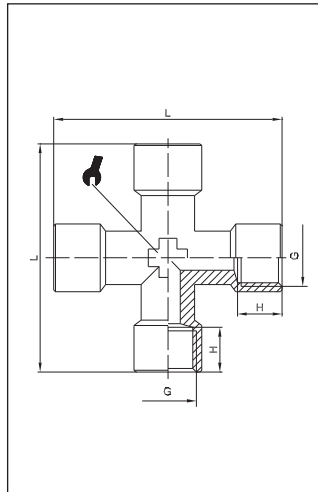

114

Kreuzstück

Female cross

| ITV | G | H | L | | |
|-------|------------------|------|----|----|----|
| 60202 | G ^{1/8} | 8 | 42 | 10 | 25 |
| 60203 | G ^{1/4} | 11 | 51 | 13 | 25 |
| 60204 | G ^{3/8} | 11,5 | 56 | 17 | 25 |
| 60205 | G ^{1/2} | 14 | 67 | 21 | 25 |

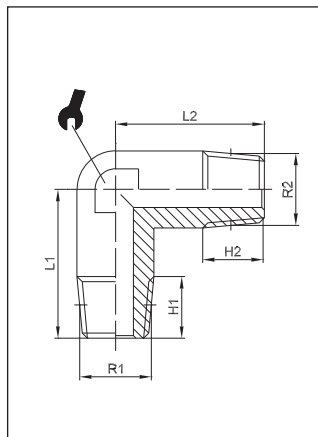

115

Winkelstück konisch

Male elbow, con.

| ITV | R1 | R2 | H1 | H2 | L1 | L2 | | |
|-------|------------------|------------------|------|------|------|------|----|-----|
| 50002 | R ^{1/8} | R ^{1/8} | 8 | 8 | 18,5 | 18,5 | 10 | 100 |
| 50008 | R ^{1/4} | R ^{1/8} | 11 | 8 | 21,5 | 19 | 10 | 100 |
| 50003 | R ^{1/4} | R ^{1/4} | 11 | 11 | 23,5 | 23,5 | 13 | 50 |
| 50004 | R ^{3/8} | R ^{3/8} | 11,5 | 11,5 | 26 | 26 | 17 | 25 |
| 50005 | R ^{1/2} | R ^{1/2} | 14 | 14 | 31 | 31 | 21 | 25 |
| 50006 | R ^{3/4} | R ^{3/4} | 16 | 16 | 33 | 33 | 25 | 10 |
| 50007 | R1 | R1 | 17 | 17 | 39 | 39 | 30 | 10 |

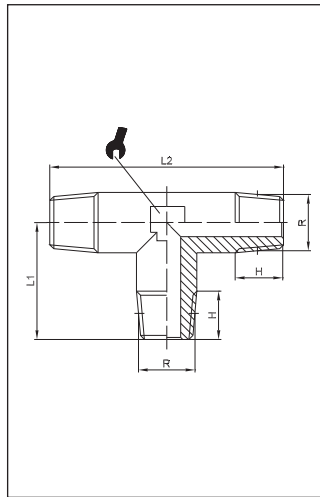

116
T-Stück konisch
Male Tee con.

| ITV | R | H | L1 | L2 | | |
|-------|------------------|------|------|------|----|-----|
| 40103 | R ^{1/8} | 8 | 18,5 | 37 | 10 | 100 |
| 40104 | R ^{1/4} | 11 | 23,5 | 47 | 13 | 50 |
| 40105 | R ^{3/8} | 11,5 | 26 | 52 | 17 | 25 |
| 40106 | R ^{1/2} | 14 | 31 | 62 | 21 | 25 |
| 40107 | R ^{3/4} | 16 | 33 | 66,4 | 25 | 10 |
| 40108 | R1 | 17,5 | 39 | 78 | 30 | 10 |

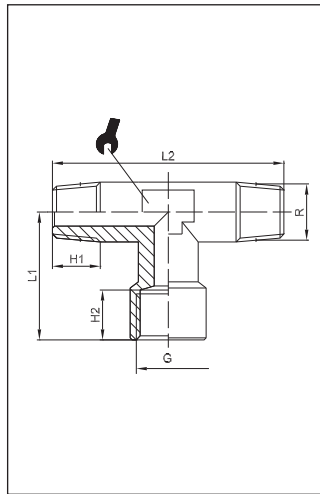

117
T-Stück konisch mit Außen-Innengewinde
Centre female tee con.

| ITV | R | G | H1 | H2 | L1 | L2 | | |
|-------|------------------|------------------|------|------|------|------|----|-----|
| 40202 | R ^{1/8} | G ^{1/8} | 8 | 8 | 21 | 37 | 10 | 100 |
| 40203 | R ^{1/4} | G ^{1/4} | 11 | 11 | 25,5 | 47 | 13 | 50 |
| 40204 | R ^{3/8} | G ^{3/8} | 11,5 | 11,5 | 28 | 52 | 17 | 25 |
| 40205 | R ^{1/2} | G ^{1/2} | 14 | 14 | 33,5 | 62 | 21 | 25 |
| 40206 | R ^{3/4} | G ^{3/4} | 16 | 16,5 | 36,5 | 66,4 | 25 | 10 |
| 40207 | R1 | G1 | 17,5 | 19 | 45 | 78 | 30 | 10 |

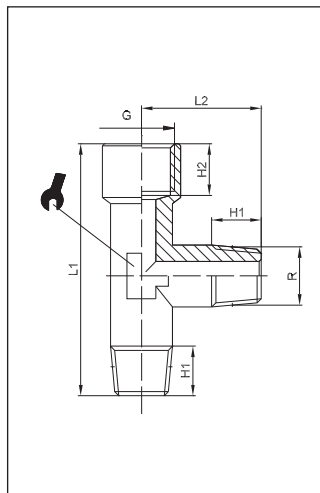

118
L-Stück konisch
Off-set female tee con.

| ITV | R | G | H1 | H2 | L1 | L2 | | |
|-------|------------------|------------------|------|------|------|------|----|-----|
| 40302 | R ^{1/8} | G ^{1/8} | 8 | 8 | 39,5 | 18,5 | 10 | 100 |
| 40303 | R ^{1/4} | G ^{1/4} | 11 | 11 | 49 | 23,5 | 13 | 50 |
| 40304 | R ^{3/8} | G ^{3/8} | 11,5 | 11,5 | 54 | 26 | 17 | 25 |
| 40305 | R ^{1/2} | G ^{1/2} | 14 | 14 | 64,5 | 31 | 21 | 25 |
| 40306 | R ^{3/4} | G ^{3/4} | 16 | 16,5 | 69,5 | 33 | 25 | 10 |
| 40307 | R1 | G1 | 17,5 | 19 | 84 | 39 | 30 | 10 |

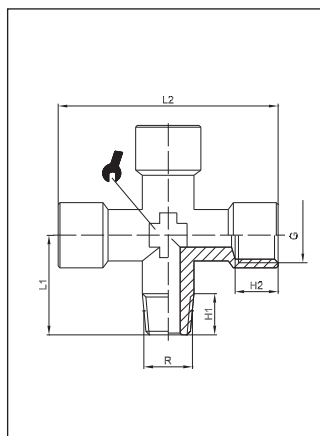

120
Kreuzstück konisch
1 male 3 female cross, con.

| ITV | R | G | H1 | H2 | L1 | L2 | | |
|-------|------------------|------------------|------|------|------|----|----|----|
| 60251 | R ^{1/8} | G ^{1/8} | 8 | 8 | 18,5 | 42 | 10 | 25 |
| 60252 | R ^{1/4} | G ^{1/4} | 11 | 11 | 23,5 | 51 | 13 | 25 |
| 60253 | R ^{3/8} | G ^{3/8} | 11,5 | 11,5 | 26 | 56 | 17 | 25 |
| 60254 | R ^{1/2} | G ^{1/2} | 14 | 14 | 31 | 67 | 21 | 25 |

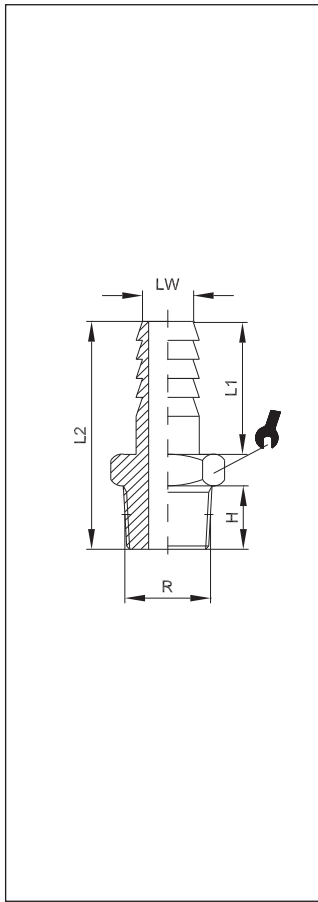

119

Schlauchtülle konisch

Male hose adapter con.

| TV | LW | R | H | L1 | L2 | | |
|-------|----|------------------|------|----|------|----|-----|
| 30402 | 6 | R ^{1/8} | 88 | 19 | 31,5 | 12 | 100 |
| 30403 | 6 | R ^{1/4} | 11 | 19 | 35 | 14 | 100 |
| 30404 | 7 | R ^{1/8} | 8 | 19 | 31,5 | 12 | 100 |
| 30405 | 7 | R ^{1/4} | 11 | 19 | 35 | 14 | 100 |
| 30406 | 8 | R ^{1/8} | 8 | 19 | 31,5 | 12 | 100 |
| 30407 | 8 | R ^{1/4} | 11 | 19 | 35 | 14 | 100 |
| 30408 | 9 | R ^{1/8} | 8 | 19 | 31,5 | 12 | 100 |
| 30409 | 9 | R ^{1/4} | 11 | 19 | 35 | 14 | 100 |
| 30410 | 9 | R ^{3/8} | 11,5 | 19 | 35,5 | 17 | 100 |
| 30411 | 9 | R ^{1/2} | 14 | 19 | 38,5 | 22 | 100 |
| 30412 | 10 | R ^{1/8} | 8 | 20 | 32,5 | 12 | 100 |
| 30413 | 10 | R ^{1/4} | 11 | 20 | 36 | 14 | 100 |
| 30414 | 10 | R ^{3/8} | 11,5 | 20 | 36,5 | 17 | 100 |
| 30415 | 10 | R ^{1/2} | 14 | 20 | 39,5 | 22 | 100 |
| 30416 | 12 | R ^{1/4} | 11 | 20 | 36 | 14 | 50 |
| 30417 | 12 | R ^{3/8} | 11,5 | 20 | 36,5 | 17 | 50 |
| 30418 | 12 | R ^{1/2} | 14 | 20 | 39,5 | 22 | 50 |
| 30419 | 14 | R ^{3/8} | 11,5 | 22 | 38,5 | 17 | 50 |
| 30420 | 16 | R ^{3/8} | 11,5 | 22 | 38,5 | 17 | 50 |
| 30421 | 14 | R ^{1/2} | 14 | 22 | 41,5 | 22 | 50 |
| 30422 | 16 | R ^{1/2} | 14 | 22 | 41,5 | 22 | 50 |
| 30426 | 17 | R ^{1/2} | 14 | 24 | 43,5 | 22 | 50 |
| 30427 | 18 | R ^{1/2} | 14 | 24 | 43,5 | 22 | 50 |

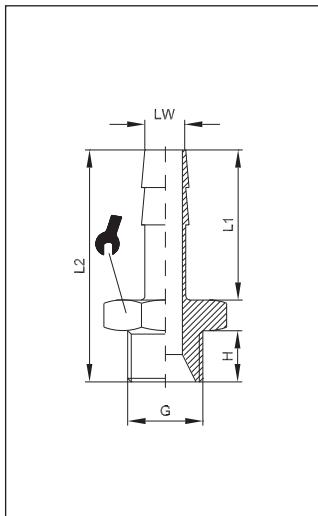

119/z

Schlauchtülle zylindrisch

Male hose adapter cyl.

| TV | LW | G | H | L1 | L2 | | |
|-------|----|------------------|----|----|------|----|-----|
| 30454 | 7 | G ^{1/8} | 6 | 19 | 29,5 | 12 | 100 |
| 30455 | 7 | G ^{1/4} | 8 | 19 | 32 | 14 | 100 |
| 30456 | 8 | G ^{1/8} | 6 | 19 | 29,5 | 12 | 100 |
| 30457 | 12 | G ^{3/8} | 9 | 20 | 34 | 19 | 100 |
| 30458 | 12 | G ^{1/2} | 10 | 20 | 35,5 | 22 | 100 |
| 30459 | 9 | G ^{1/4} | 8 | 19 | 33 | 14 | 100 |
| 30460 | 9 | G ^{1/8} | 6 | 19 | 29,5 | 12 | 100 |
| 30462 | 9 | G ^{3/8} | 9 | 19 | 33 | 19 | 100 |
| 30461 | 12 | G ^{1/4} | 8 | 20 | 33 | 14 | 50 |

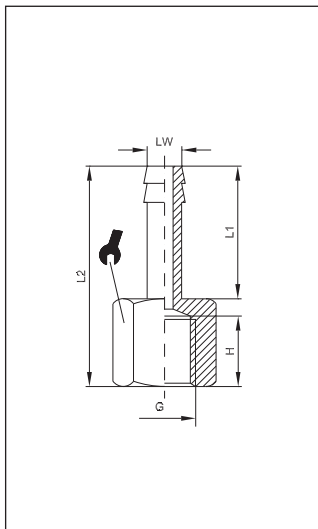

122

Schlauchtülle mit Innengewinde

Female hose adapter

| TV | LW | G | H | L1 | L2 | | |
|-------|----|------------------|------|------|------|----|-----|
| 30502 | 6 | G ^{1/8} | 8,5 | 19,5 | 30 | 14 | 100 |
| 30503 | 7 | G ^{1/8} | 8,5 | 19,5 | 30 | 14 | 100 |
| 30513 | 7 | G ^{1/4} | 11 | 19,5 | 32,5 | 17 | 100 |
| 30504 | 8 | G ^{1/4} | 11 | 19,5 | 32,5 | 17 | 100 |
| 30505 | 9 | G ^{1/4} | 11 | 19,5 | 32,5 | 17 | 100 |
| 30507 | 10 | G ^{3/8} | 11,5 | 19,5 | 33,5 | 20 | 100 |
| 30510 | 12 | G ^{3/8} | 11,5 | 19,5 | 33,5 | 20 | 100 |
| 30511 | 12 | G ^{1/2} | 14,5 | 19,5 | 37,5 | 24 | 100 |

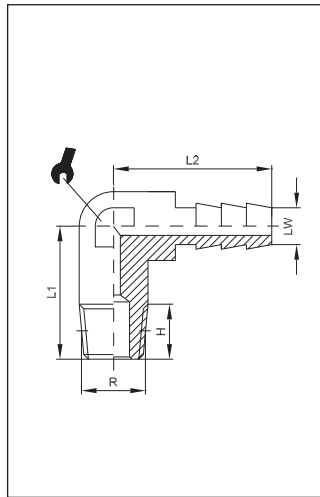

121

Winkelschraubversch. mit Schlauchaufnahme

Elbow connector for tubes

| ITV | R | LW | H | L1 | L2 | | |
|-------|------------------|----|----|------|------|----|-----|
| 51000 | R ^{1/8} | 6 | 8 | 18,5 | 21,5 | 9 | 100 |
| 51001 | R ^{1/8} | 9 | 11 | 20 | 24 | 11 | 100 |
| 51002 | R ^{1/4} | 6 | 11 | 22 | 22,5 | 10 | 100 |
| 51003 | R ^{1/4} | 8 | 11 | 22 | 22,5 | 10 | 100 |
| 51004 | R ^{1/4} | 9 | 11 | 22 | 24 | 11 | 100 |

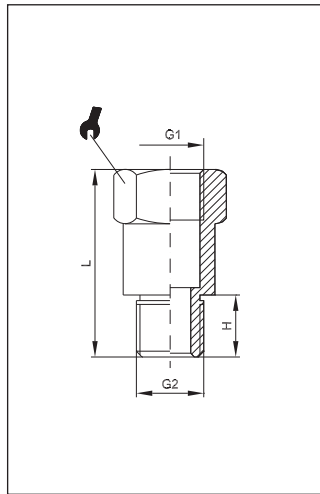

123

Verlängerung Innen-Außen zylindrisch

Extension cyl.

| ITV | G1 | G2 | H | L | | |
|-------|------------------|------------------|---|----|----|-----|
| 20702 | G ^{1/8} | G ^{1/8} | 6 | 22 | 14 | 100 |
| 20703 | G ^{1/8} | G ^{1/8} | 6 | 42 | 14 | 100 |
| 20704 | G ^{1/4} | G ^{1/4} | 8 | 35 | 17 | 100 |
| 20705 | G ^{1/4} | G ^{1/4} | 8 | 51 | 17 | 100 |

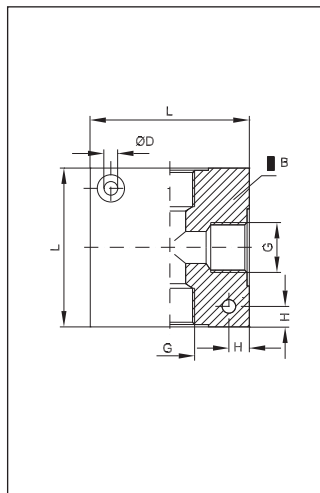
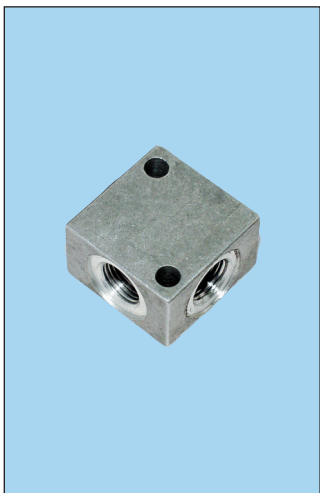

124

Verteilerblock aus Aluminium

Aluminium cross manifold

| ITV | G | ØD | B | H | L | |
|-------|------------------|-----|----|---|----|----|
| 60402 | G ^{1/8} | 4,5 | 15 | 4 | 25 | 25 |
| 60403 | G ^{1/4} | 5,5 | 20 | 7 | 40 | 25 |
| 60404 | G ^{3/8} | 5,5 | 25 | 8 | 50 | 25 |
| 60405 | G ^{1/2} | 5,5 | 30 | 8 | 50 | 25 |

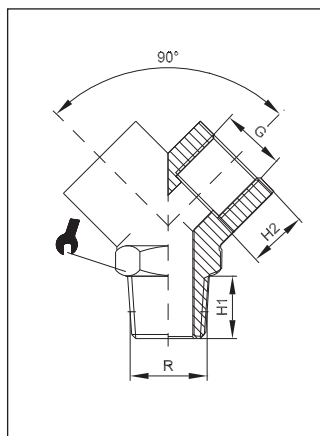

125

Y-Verteiler konisch

M/F Y-connector con.

| ITV | R | G | H1 | H2 | | |
|-------|------------------|------------------|------|------|----|----|
| 60002 | R ^{1/8} | G ^{1/8} | 8 | 8 | 13 | 50 |
| 60003 | R ^{1/4} | G ^{1/4} | 11 | 11 | 17 | 50 |
| 60004 | R ^{3/8} | G ^{3/8} | 11,5 | 11,5 | 20 | 25 |
| 60005 | R ^{1/2} | G ^{1/2} | 14 | 14 | 25 | 25 |

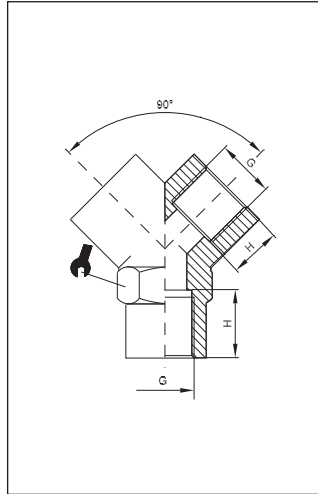

126

Y-Verteiler

Female Y-connector

| TV | G | H | | |
|-------|-------------------------------|------|----|----|
| 60102 | G ¹ / ₈ | 8 | 13 | 50 |
| 60103 | G ¹ / ₄ | 11 | 17 | 50 |
| 60104 | G ³ / ₈ | 11,5 | 20 | 25 |
| 60105 | G ¹ / ₂ | 14 | 25 | 25 |

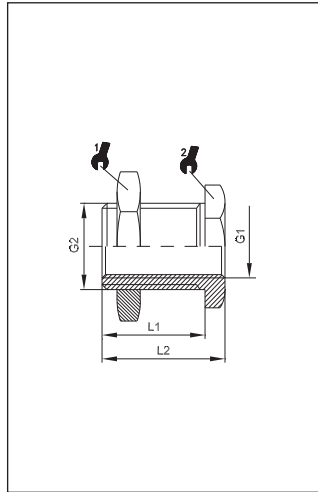

127

Schottverschraubung

Bulkhead union

| TV | G1 | G2 | L1 | L2 | | | |
|---------|-------------------------------|---------|------|----|----|----|-----|
| 30601-1 | M5 | M10x1 | 10,5 | 14 | 14 | 14 | 100 |
| 30602-1 | G ¹ / ₈ | M16x1,5 | 14 | 18 | 22 | 19 | 100 |
| 30603-1 | G ¹ / ₄ | M20x1,5 | 21 | 25 | 27 | 24 | 100 |
| 30604-1 | G ³ / ₈ | M26x1,5 | 21 | 26 | 32 | 30 | 50 |
| 30605-1 | G ¹ / ₂ | M28x1,5 | 27 | 33 | 36 | 32 | 25 |

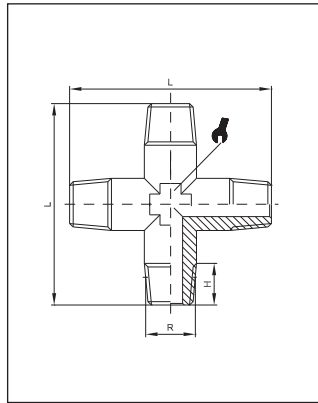

128

Kreuzstück konisch

Male cross

| TV | R | H | L | | |
|-------|-------------------------------|------|----|----|----|
| 60302 | R ¹ / ₈ | 8 | 35 | 11 | 25 |
| 60303 | R ¹ / ₄ | 11 | 47 | 13 | 25 |
| 60304 | R ³ / ₈ | 11,5 | 52 | 17 | 25 |
| 60305 | R ¹ / ₂ | 14 | 58 | 20 | 25 |

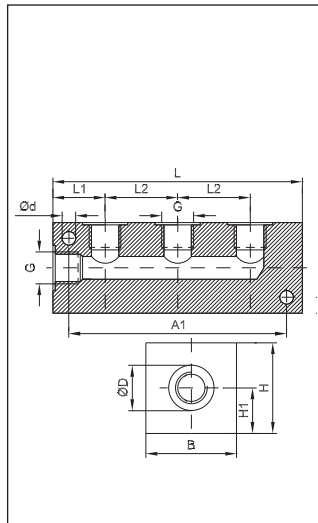

129

Verteilerleiste 3-fach

3-connection block

| TV | G | ØD | H | B | L | L1 | L2 | |
|-------|-------------------------------|------|-----|----|-----|------|----|----|
| 12900 | M5 | 8,5 | 15 | 15 | 40 | 10 | 10 | 10 |
| 12901 | G ¹ / ₈ | 14,5 | 20 | 20 | 56 | 13,5 | 17 | 10 |
| 12902 | G ¹ / ₄ | 19 | 30 | 30 | 89 | 20 | 29 | 5 |
| 12903 | G ³ / ₈ | 23 | 40 | 30 | 85 | 20 | 26 | 5 |
| 12904 | G ¹ / ₂ | 27,5 | 40 | 30 | 105 | 25 | 32 | 1 |
| | H1 | A1 | Ød | | | | | |
| 12900 | 5 | 32 | 3,4 | | | | | |
| 12901 | 8 | 46 | 4,4 | | | | | |
| 12902 | 13 | 74 | 6,4 | | | | | |
| 12903 | 21 | 72 | 6,4 | | | | | |
| 12904 | 18 | 90 | 6,4 | | | | | |

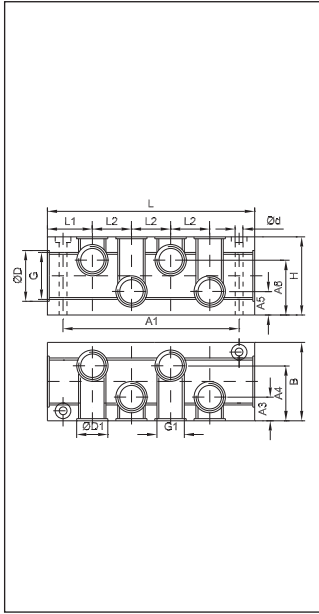

130
Verteilerleiste 8-fach
8-connection block

| ITV | G | ØD | G1 | ØD1 | B | H | L | L1 | ■ |
|-------|-------------------------------|------|-------------------------------|------|----|----|-----|------|----|
| 60311 | G ¹ / ₄ | 19 | M5 | 8,5 | 32 | 25 | 65 | 17,5 | 10 |
| 60312 | G ³ / ₈ | 23 | G ¹ / ₈ | 14,5 | 40 | 30 | 114 | 22,5 | 5 |
| 60313 | G ¹ / ₂ | 27,5 | G ¹ / ₄ | 19 | 50 | 35 | 144 | 28,5 | 1 |
| 60314 | G ³ / ₄ | 34 | G ¹ / ₂ | 27,5 | 60 | 45 | 170 | 31 | 1 |

| | L2 | A1 | A3 | A4 | A5 | A6 | Ød |
|-------|----|-----|------|------|------|------|-----|
| 60311 | 10 | 50 | 12,5 | 19,5 | 8,5 | 16,5 | 4,4 |
| 60312 | 23 | 100 | 16,5 | 24,5 | 10,5 | 19,5 | 6,5 |
| 60313 | 29 | 128 | 20,5 | 29,5 | 13 | 22 | 6,5 |
| 60314 | 36 | 150 | 27 | 33 | 19,5 | 25,5 | 8,5 |

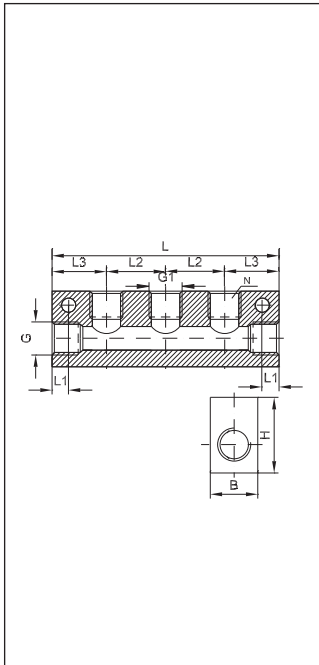
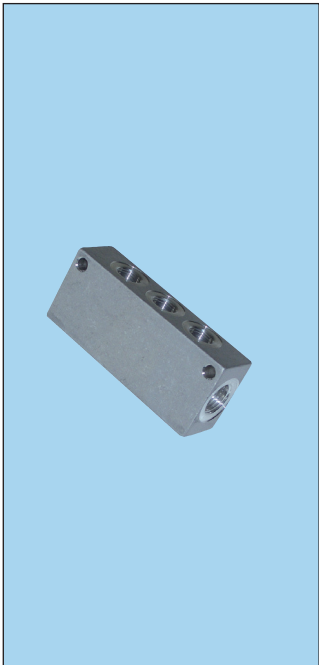

131
Durchgangsleiste
Through-going block

| ITV | G | G1 | B | H | L1 | L2 | L3 | L | N | ■ |
|-------|-------------------------------|-------------------------------|----|----|-----|----|----|-----|---|----|
| 60411 | G ¹ / ₄ | G ¹ / ₈ | 20 | 30 | 4,5 | 18 | 18 | 54 | 2 | 10 |
| 60412 | G ¹ / ₄ | G ¹ / ₈ | 20 | 30 | 4,5 | 18 | 18 | 72 | 3 | 10 |
| 60413 | G ¹ / ₄ | G ¹ / ₈ | 20 | 30 | 4,5 | 18 | 18 | 90 | 4 | 10 |
| 60414 | G ¹ / ₄ | G ¹ / ₈ | 20 | 30 | 4,5 | 18 | 18 | 108 | 5 | 5 |
| 60415 | G ³ / ₈ | G ¹ / ₄ | 25 | 40 | 8,5 | 24 | 22 | 68 | 2 | 5 |
| 60416 | G ³ / ₈ | G ¹ / ₄ | 25 | 40 | 8,5 | 24 | 22 | 92 | 3 | 5 |
| 60417 | G ³ / ₈ | G ¹ / ₄ | 25 | 40 | 8,5 | 24 | 22 | 116 | 4 | 5 |
| 60418 | G ³ / ₈ | G ¹ / ₄ | 25 | 40 | 8,5 | 24 | 22 | 140 | 5 | 5 |

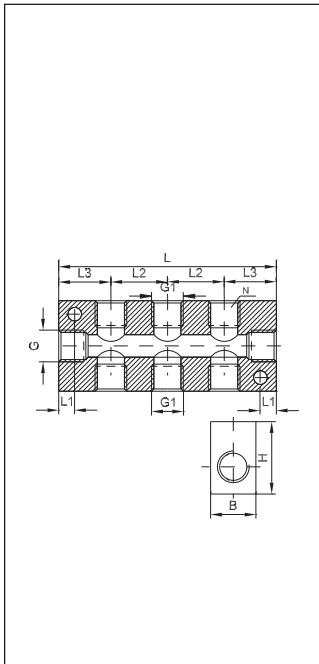

132
Durchgangsleiste
Through-going block

| ITV | G | G1 | B | H | L1 | L2 | L3 | L | N | ■ |
|-------|-------------------------------|-------------------------------|----|----|-----|----|----|-----|-----|----|
| 61411 | G ¹ / ₄ | G ¹ / ₈ | 20 | 30 | 4,5 | 18 | 18 | 54 | 2+2 | 10 |
| 61412 | G ¹ / ₄ | G ¹ / ₈ | 20 | 30 | 4,5 | 18 | 18 | 72 | 3+3 | 10 |
| 61413 | G ¹ / ₄ | G ¹ / ₈ | 20 | 30 | 4,5 | 18 | 18 | 90 | 4+4 | 10 |
| 61414 | G ¹ / ₄ | G ¹ / ₈ | 20 | 30 | 4,5 | 18 | 18 | 108 | 5+5 | 5 |
| 61415 | G ³ / ₈ | G ¹ / ₄ | 25 | 40 | 8,5 | 24 | 22 | 68 | 2+2 | 5 |
| 61416 | G ³ / ₈ | G ¹ / ₄ | 25 | 40 | 8,5 | 24 | 22 | 92 | 3+3 | 5 |
| 61417 | G ³ / ₈ | G ¹ / ₄ | 25 | 40 | 8,5 | 24 | 22 | 116 | 4+4 | 5 |
| 61418 | G ³ / ₈ | G ¹ / ₄ | 25 | 40 | 8,5 | 24 | 22 | 140 | 5+5 | 5 |

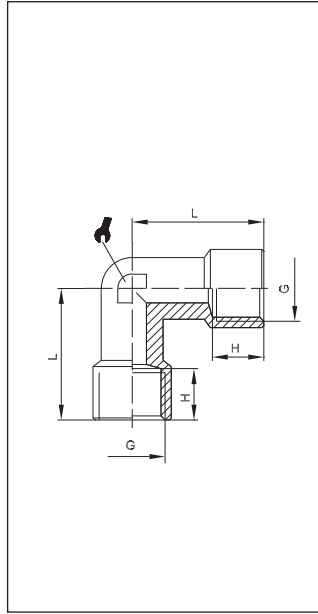

109 blank

Winkelstück

Female elbow

| TV | G | H | L | | |
|--------|------------------|------|------|----|-----|
| R50102 | G ^{1/8} | 8 | 21 | 10 | 100 |
| R50103 | G ^{1/4} | 11 | 25,5 | 13 | 50 |
| R50104 | G ^{3/8} | 11,5 | 28 | 17 | 25 |
| R50105 | G ^{1/2} | 14 | 33,5 | 21 | 25 |
| R50106 | G ^{3/4} | 16,5 | 36,5 | 25 | 25 |
| R50107 | G1 | 19 | 45 | 30 | 25 |

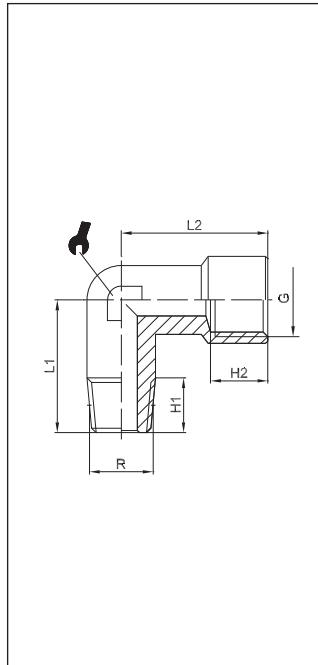

110 blank

Winkelstück

Male-female elbow

| TV | R | G | H1 | H2 | L1 | L2 | | |
|--------|------------------|------------------|------|------|------|------|----|-----|
| R50202 | R ^{1/8} | G ^{1/8} | 8 | 8 | 18,5 | 21 | 10 | 100 |
| R50203 | R ^{1/4} | G ^{1/4} | 11 | 11 | 23,5 | 25,5 | 13 | 50 |
| R50204 | R ^{3/8} | G ^{3/8} | 11,5 | 11,5 | 26 | 28 | 17 | 25 |
| R50205 | R ^{1/2} | G ^{1/2} | 14 | 14 | 31 | 33,5 | 21 | 25 |
| R50206 | R ^{3/4} | G ^{3/4} | 16 | 16,5 | 33 | 36,5 | 25 | 10 |
| R50207 | R1 | G1 | 17 | 19 | 39 | 45 | 30 | 10 |

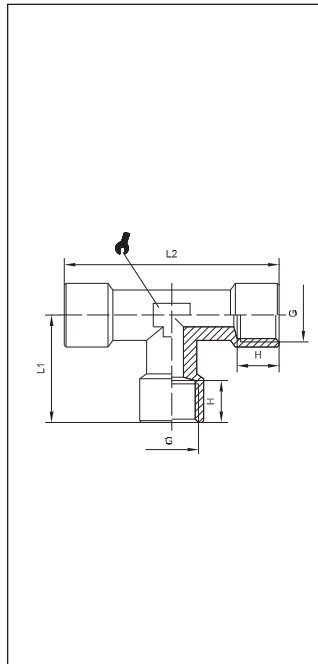

111 blank

T-Stück

Female T

| TV | G | H | L1 | L2 | | |
|--------|------------------|------|------|----|----|-----|
| R40003 | G ^{1/8} | 8 | 21 | 42 | 10 | 100 |
| R40004 | G ^{1/4} | 11 | 25,5 | 51 | 13 | 50 |
| R40005 | G ^{3/8} | 11,5 | 28 | 56 | 17 | 25 |
| R40006 | G ^{1/2} | 15 | 33,5 | 67 | 21 | 25 |
| R40007 | G ^{3/4} | 16,5 | 36,5 | 73 | 25 | 10 |
| R40008 | G1 | 19 | 45 | 90 | 30 | 10 |

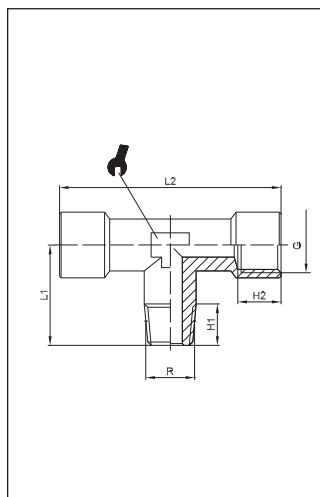

112 blank

T-Stück konisch

Centre male Tee, con.

| <i>ITV</i> | R | G | H1 | H2 | L1 | L2 | | |
|------------|-------------------------------|-------------------------------|------|------|------|----|----|-----|
| R40402 | R ¹ / ₈ | G ¹ / ₈ | 8 | 8 | 18,5 | 42 | 10 | 100 |
| R40403 | R ¹ / ₄ | G ¹ / ₄ | 11 | 11 | 23,5 | 51 | 13 | 50 |
| R40404 | R ³ / ₈ | G ³ / ₈ | 11,5 | 11,5 | 26 | 56 | 17 | 25 |
| R40405 | R ¹ / ₂ | G ¹ / ₂ | 14 | 14 | 31 | 67 | 21 | 25 |
| R40406 | R ³ / ₄ | G ³ / ₄ | 16 | 16,5 | 33 | 73 | 25 | 10 |
| R40407 | R1 | G1 | 17,5 | 19 | 39 | 90 | 30 | 10 |

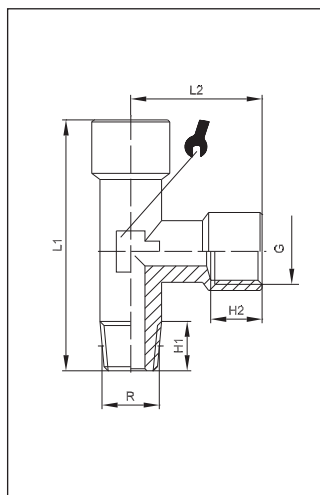

113 blank

L-Stück konisch

Off-set male T-MFF, con.

| <i>ITV</i> | R | G | H1 | H2 | L1 | L2 | | |
|------------|-------------------------------|-------------------------------|------|------|------|------|----|-----|
| R40502 | R ¹ / ₈ | G ¹ / ₈ | 8 | 8 | 39,5 | 21 | 10 | 100 |
| R40503 | R ¹ / ₄ | G ¹ / ₄ | 10 | 11,5 | 49 | 25,5 | 13 | 50 |
| R40504 | R ³ / ₈ | G ³ / ₈ | 11,5 | 11,5 | 54 | 28 | 17 | 25 |
| R40505 | R ¹ / ₂ | G ¹ / ₂ | 14,5 | 14 | 64,5 | 33 | 21 | 25 |
| R40506 | R ³ / ₄ | G ³ / ₄ | 16 | 15,5 | 69,5 | 36,5 | 25 | 10 |
| R40507 | R1 | G1 | 17,5 | 16,5 | 87 | 45 | 30 | 10 |

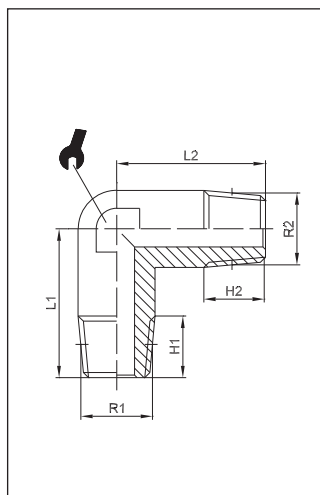

115 blank

Winkelstück konisch

Male elbow, con.

| <i>ITV</i> | R1 | R2 | H1 | H2 | L1 | L2 | | |
|------------|-------------------------------|-------------------------------|------|------|------|------|----|-----|
| R50002 | R ¹ / ₈ | R ¹ / ₈ | 8 | 8 | 18,5 | 18,5 | 10 | 100 |
| R50003 | R ¹ / ₄ | R ¹ / ₄ | 11 | 11 | 23,5 | 23,5 | 13 | 50 |
| R50004 | R ³ / ₈ | R ³ / ₈ | 11,5 | 11,5 | 26 | 26 | 17 | 25 |
| R50005 | R ¹ / ₂ | R ¹ / ₂ | 14 | 14 | 31 | 31 | 21 | 25 |
| R50006 | R ³ / ₄ | R ³ / ₄ | 16 | 16 | 33 | 33 | 25 | 10 |
| R50007 | R1 | R1 | 17 | 17 | 39 | 39 | 30 | 10 |

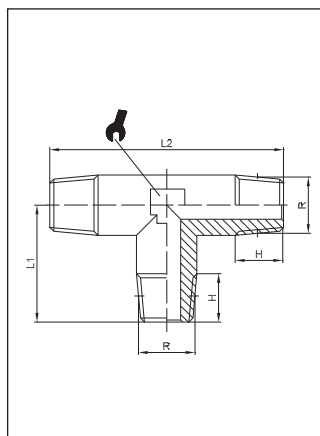

116 blank

T-Stück konisch

Male Tee, con.

| <i>ITV</i> | R | H | L1 | L2 | | |
|------------|-------------------------------|------|------|------|----|----|
| R40104 | R ¹ / ₄ | 11 | 23,5 | 47 | 13 | 50 |
| R40105 | R ³ / ₈ | 11,5 | 26 | 52 | 17 | 25 |
| R40106 | R ¹ / ₂ | 14 | 31 | 62 | 21 | 25 |
| R40107 | R ³ / ₄ | 16 | 33 | 66,4 | 25 | 10 |
| R40108 | R1 | 17,5 | 39 | 78 | 30 | 10 |